

The CONTACTOR™

Published Monthly by Optimized Gas Treating, Inc.
Volume 9, Issue 7, July, 2015

Phosphoric Acid and Amines that Form Carbamate

Commercially, phosphoric acid is used as a stripping promoter only with tertiary and possibly hindered amines. As explained later, the reason is that the formation of hard-to-decompose carbamate by amines that react with carbon dioxide negates the effect of stripping promoters. But what if there's no CO₂ present, or it's in quite small concentration?

How Stripping Promoters Work

Stripping promoters like phosphoric acid work at the lean end of the stripper where acid gas loadings are already low. Their purpose is to lower the lean loadings even further and relieve the lean loading limitation on the amount of removal possible in the absorber. The main reaction for regeneration of H₂S from a secondary amine is

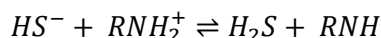

For CO₂ in a secondary amine:

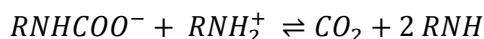

Phosphoric acid in water dissociates (but not completely) to form three different ions: H₂PO₄⁻¹, HPO₄⁻², and PO₄⁻³. Each dissociation reaction also produces a hydrogen ion, and each hydrogen ion neutralizes an amine molecule:



At this point we have to use a little physical chemistry, namely, Le Châtelier's Principle—this says if you increase the concentration of a component on one side of an equilibrium reaction, it will drive the equilibrium towards the opposite side of the equation[†]. In the present context, adding a little hydrogen ion by acid-neutralizing part of the amine increases the RNH₂⁺ concentration on the left

[†] Reaction equilibrium constants are functions of temperature, but only weakly dependent on composition. Altering the composition of one component forces all the others to adjust so that the value of the equilibrium constant stays the same. Solution nonidealities have a minor effect and only to the extent that activity coefficients are concentration dependent.

side of the H₂S and CO₂ equations above, and this pushes the equilibria to the right, i.e., towards the formation of more acid gases in their free forms which can then desorb, or strip from the solvent.

So why is phosphoric acid not normally used with primary and secondary amines, i.e., with amines that form carbamate? The reason is that when there is significant carbon dioxide in the gas being treated, it's impossible to strip to really low residual CO₂ concentrations because carbamate is somewhat heat stable and resists thermal decomposition. Therefore, a substantial carbamate concentration is usually left in solution in the reboiler, with a substantial protonated amine concentration to go with it. Thus adding a little more protonation to a solution that is already fairly well protonated will have at best only a marginal effect, and at worst, no effect at all. On the other hand, if there is very little CO₂ in the system to begin with, adding a little more protonation represents a large relative total increase, so the effect is potentially a large one.

Systems with Low Carbon Dioxide

Refineries are one place where one is likely to find gases containing mostly H₂S with very little carbon dioxide, and DEA is still a commonly used solvent. A case study is the most straightforward way to demonstrate the effect.

Figure 1 shows a schematic of the simple absorber and regenerator setup. This is a simplified version of a more complex treating application in which there are actually multiple absorbers and liquid treaters. The absorber contains 20 standard valve-type trays and is treating about 34,000 Nm³/h of gas with 12.2 mol% H₂S and 0.47 mol% CO₂ at 12.5 barg and 32°C. The solvent is 390,000 kg/h of 26.5 wt% DEA with 3,200 ppmw formate equivalent (heat stable salt). The absorber runs at about 50% of jet and downcomer choke flooding. The regenerator has 3

wash trays and 20 stripping trays. The stripping trays run at 28% and 20% of jet and downcomer flood, respectively, while the wash trays are at only 16% of jet flooding so they are probably weeping much of the reflux water through the valves.

Figure 2 shows how the residual H_2S level in the treated gas varies with the amount of phosphoric acid in the solvent (in increments of 5,000 ppmw H_3PO_4), while Figure 3 shows how adding phosphoric acid dramatically drops lean loadings. Incidentally, simulation showed the effect of phosphoric acid on the CO_2 level in the treated gas was negligible. It is also worth mentioning that in all cases the absorber was completely lean end pinch with respect to hydrogen sulfide absorption — the final H_2S level in the treated gas was fully achieved across just the bottom 10 absorber trays. In other words, treating with respect to H_2S is set by the composition and temperature of the lean solvent. Carbon dioxide was absorbed throughout the entire column to an extent that was set by mass transfer rate limitations, not by lean loading.

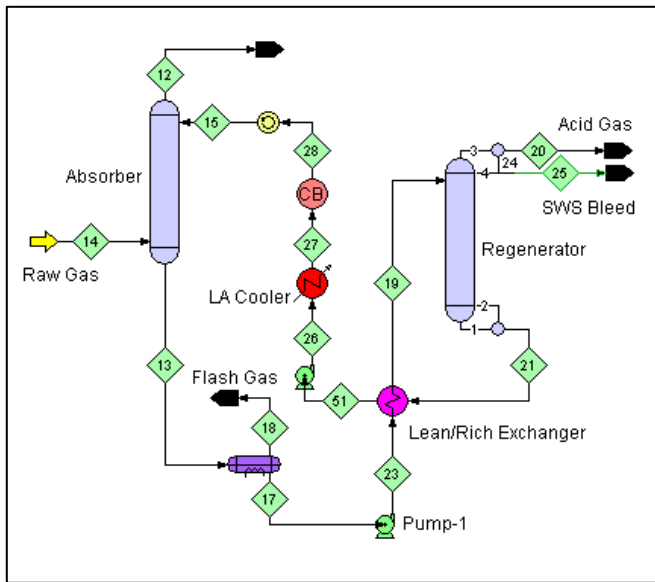

Figure 1 DEA Amine Treating System

The levels of phosphoric acid used here are up to several times the concentrations commonly used with MDEA in selective (tail gas, AGE) treating. This may be undesirable from a corrosion standpoint (remember the penny in the Coca Cola experiment); nevertheless, Figure 2 shows that using phosphoric acid can significantly lower sulfur emissions from, for example, a fuel gas treater. The more complete removal and emissions reduction is achieved, not by using more reboiler or

regenerator energy, but simply by manipulating the basic chemistry.

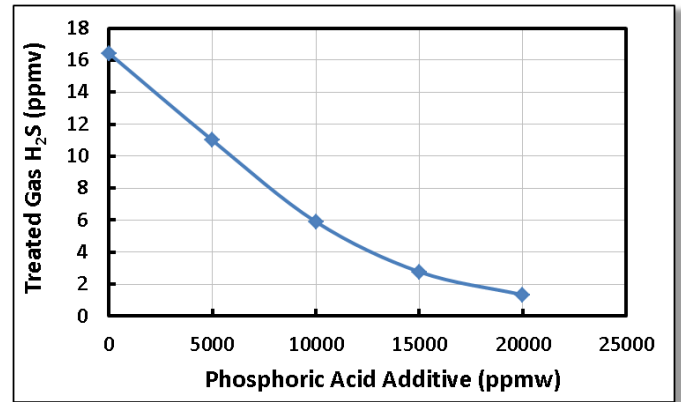

Figure 2 Effect of H_3PO_4 on H_2S Treating

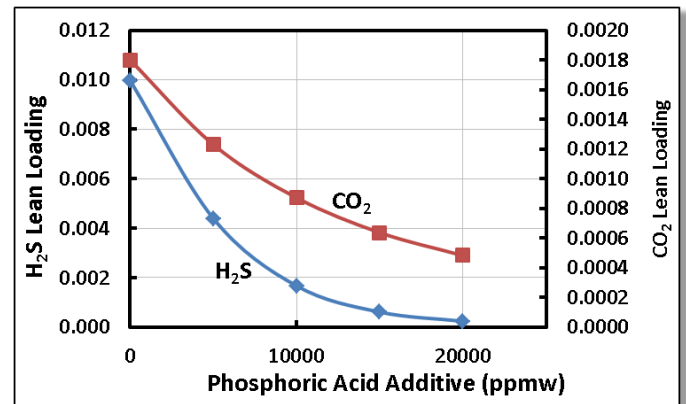

Figure 3 Effect of H_3PO_4 on Lean Loadings

A real mass transfer rate based simulator is an excellent tool for allowing one to make “new discoveries” about gas treating. Its power lies in the fact that it is really a virtual plant on a computer because the model contains all the essential elements that determine treating plant performance. Key among these are the mass transfer characteristics of the tower internals and a detailed, accurate, assessment of phase equilibrium and the important role played in phase equilibrium by the solvent’s ionic speciation.

To learn more about this and other aspects of gas treating, plan to attend one of our training seminars. Visit www.protreat.com/seminars for details.

ProTreat® and **The Contactor™** are trademarks of Optimized Gas Treating, Inc.