

Reliable design of sour water strippers

A simulation model aims to raise confidence in the reliability of sour water stripper design

NATHAN HATCHER and RALPH WEILAND
Optimized Gas Treating

Oil refining always generates sour water, and within a refinery there are numerous sources. Most refinery sour water systems contain very little CO_2 . The H_2S content makes water “sour”, and H_2S levels can become very high. The capacity of ammonia solutions for H_2S is a direct result of ammonia’s alkalinity, which neutralises the hydrogen ion liberated by H_2S dissociation when it dissolves into the solution. Although not the usual case, in principle, and with enough H_2S partial pressure, there can even be more H_2S than ammonia. The potentially very high H_2S content can make sour water extremely foul and, if the H_2S is not recovered, pollution levels would be completely out of hand. Many sour⁴ water sources have been noted.¹ Sources include the following:

- Many refining units use live steam and heat for fractionation, and live steam for velocity assist and temperature control in fired heaters. Nitrogen in the presence of heat and a hydrogen source (such as a hydrocarbon) forms ammonia.

The steam is condensed and recovered in the overhead circuit of the crude unit, FCC unit or coker unit

- In the case of refinery hydrotreating, hydrogen gas and a metal catalyst are used to saturate olefins. Hydrotreating also converts sulphur-containing hydrocarbons to H_2S , and nitrogen-bearing hydrocarbons to ammonia

- Although ammonia is considerably more volatile than most alkanolamines, it has a high affinity for water. Ammonia is removed from hydrocarbon products by injecting wash water into the gas and cooling the mixture at an elevated pressure to condense the water. This provides an irresistible invitation for ammonia to enter the aqueous phase

- Wash water prevents the accumulation of salts and the corrosion of heat exchange surfaces, especially in areas where there are gas liquid interfaces and where there are sudden temperature changes on heat transfer surfaces, such as when heat transfer is controlled by liquid level in an exchanger

- Amine regenerator reflux water purges can also be a significant source of ammonia.

The sour water generated in refineries is generally classified as being either phenolic or non-phenolic. Non-phenolic water contains almost exclusively NH_3 , H_2S and possibly a trace of CO_2 ; it is generated by refinery hydrotreating (hydrodesulphurisation, or HDS) units. When stripped of contaminants, non-phenolic water can typically be recycled for reuse in the HDS as wash water, or it can be used as make-up water to the crude desalting process. This article considers only non-phenolic water. Phenolic (or, more broadly, non-HDS) water contains compounds that can harm upstream units if used as wash water in them. Typical contaminants include salts, phenols and caustic. However, make-up water to processing units must first be treated, so maximising water reuse is desirable to minimise attendant operating costs. Other sources of water to sour water stripping units are process drums, crude desalting units,

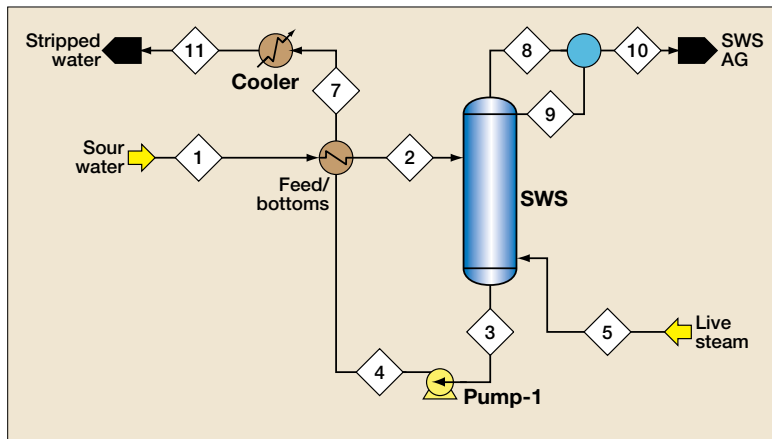

Figure 1 Sour water stripper with live steam injection

scrubbing of hydrocarbons following caustic treatment for mercaptans, COS and final H₂S removal, TGU quench columns, and various effluent drains for removing the water used to prevent salt deposition in equipment.¹

It may be useful to point out that ammonia and hydrogen sulphide have almost unlimited solubility in water when they are present together. This is a possibly interesting consequence of the fact that the reactive component of the solvent, ammonia, is volatile and, if present in the gas phase, it will continue to absorb as long as it becomes protonated as a result of H₂S co-absorption. Thus, it is conceivable that a particular sour water stream may be a lot more concentrated in both ammonia and hydrogen sulphide than the solubility of either component alone would suggest.

Basic sour water stripping process

At first glance, sour water stripping is a simple process in which either external steam, steam generated by a reboiler,

or even a hot hydrocarbon stripping vapour is used to shift chemical reaction equilibria by heating the sour water. Stripping vapour is the “gaseous solvent” used to remove and carry the ammonia and H₂S out of the system. In other words, the application of heat generates internal stripping steam (equivalently, live steam injection or stripping gas can be used) and removes ammonia, H₂S and CO₂ from the water by:

- Heating the sour water feed to boiling point
- Reversing chemical reactions
- Diluting the partial pressure of the gases stripped by furnishing excess steam.

The process is very similar to amine regeneration. Figure 1 shows a typical sour water stripper column with heating by the injection of live steam. Since a sour water stripper does not form a closed loop in the same sense that an amine regenerator does, maintaining a water balance is unnecessary. This means that live steam can be used as a stripping agent either alone or in conjunction with a conventional reboiler, and the additional water added

by the condensate is simply added to the refinery’s water inventory. Typical energy usage in the stripping process is in the range 1.0-1.5 lb of 50 psig equivalent saturated steam per gallon of sour water.

When an external reboiler is used, steam pressure can often be higher than in an amine regenerator to minimise the heat exchange surface. In an amine regenerator, amine degradation limits temperatures. In a sour water stripper, there is little or no ammonia in the stripped water in the reboiler, so these concerns do not exist. However, there is a practical limit of 400-450°F, where coking heavy hydrocarbons can lead to fouling and solids deposition in the reboiler. Corrosion is always a concern.

Higher NH₃ and H₂S concentrations require more stripping energy. Since H₂S solubility relies on the presence of ammonia, the molar concentration of H₂S very rarely exceeds that of ammonia, and then usually only in dilute systems. A typical molar ratio of H₂S to ammonia is 0.5-0.8 in the combined sour water stripper feed water of a typical refinery. Ammonia levels in the water are often determined by upstream process conditions, and they can be highly specific to the process licensors and crude slate in operation. Obviously, higher concentrations of NH₃ and H₂S are preferred from a water consumption perspective. However, there is a practical limit of between one and several weight per cent ammonium bisulphide equivalent in the sour water feed before metallurgy must be upgraded.

Trays have historically been used in sour water strippers, but random packing is beginning to see use in units processing relatively clean water. Trays with directional, fixed valves have been reported to be more resistant to fouling, because the horizontal velocity imparted as the gas leaves each valve tends to sweep clean the area near the valves.²

Stripped sour water specifications for NH₃ and H₂S can be highly dependent upon the locale where the unit is installed and the final discharge requirements. NH₃ is harder to strip than H₂S, and typical targets for NH₃ are 30-80 ppmw in the stripped water versus undetectable to less than 0.1 ppmw for H₂S. Typical recent installations^{3,4} involve 35-45 actual trays, with overall tray efficiencies quoted anywhere from 25 to 45%.

Chemistry of ammonia with acid gases

Ammonia is a relatively weak base capable of being mono-protonated. For example, in aqueous solution, it forms ammonium ion (protonated ammonia) to a limited extent:



This reaction is in perfect parallel with amine protonation, so in this sense ammonia can be thought of as nothing more than just another reactive amine. There is a great deal of nonsense written in various books and other publications concerning the reactions of H₂S and CO₂ with ammonia. All reactions involve ionic species and all reaction products are ions. Ions do not form ionic

compounds except possibly when materials begin to precipitate. As long as all species are in solution, they exist as individual ions and are not associated with each other. All ions are freely floating and the only associations are ones that result in solution non-ideality. Thus, there is no such thing as ammonium carbonate, ammonium bicarbonate, ammonium bisulphide or diammonium sulphide in solution. It is very hard to make sense of reaction equilibria unless one discards the existence of such compounds.

The reactions that occur when H₂S and CO₂ dissolve in solution are the same as in any other aqueous, primary or secondary amine system. The reactions are:

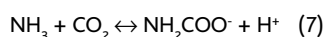
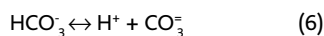
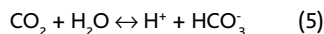
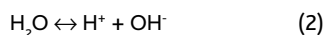

Ammonia drives all these reactions to the right by serving as a proton sink per reaction (1). Understanding sour water strippers, understanding the way ammonia behaves as a solvent for acid gases, and understanding what happens to ammonia in amine regenerators depends on knowledge of:

- Vapour-liquid equilibria
- Kinetics of the carbamate-forming reaction, Equation 7
- An appreciation for mass transfer as a rate process

where Henry's Law applies.

The thermodynamic framework on which the vapour-liquid calculations are based involves a model for the activity coefficients via extended Debye-Hückel theory. Thus, the basic modelling approach for ammonia is the same as for any other amine, with one exception: ammonia is highly volatile and this leads to different distributions in absorption and especially regeneration equipment compared with amines. Its volatility is often responsible for it getting into the sour water system in the first place (through condenser water blow-down, for example), but volatility also allows it to be recovered relatively easily from the same sour water. Heat stable salts and alkali salt contaminants also affect the distribution of ionic species in solution and their presence must be considered, too, and is the subject of a future article.

Simulating sour water strippers

Traditionally, sour water strippers have been modelled as a series of equilibrium stages, with overall stage efficiencies quoted anywhere in the range of 15% to 45%; that is, ranging over a factor of three. However, the mass transfer rate-based approach to the simulation of amine contactors and such hard-to-model distillation processes as extractive, azeotropic and reactive distillation have been in commercial use since the mid- to late 1980s. Their extension to sour water stripping is a natural progression and, in December, 2011 a commercial mass transfer rate-based sour water stripper

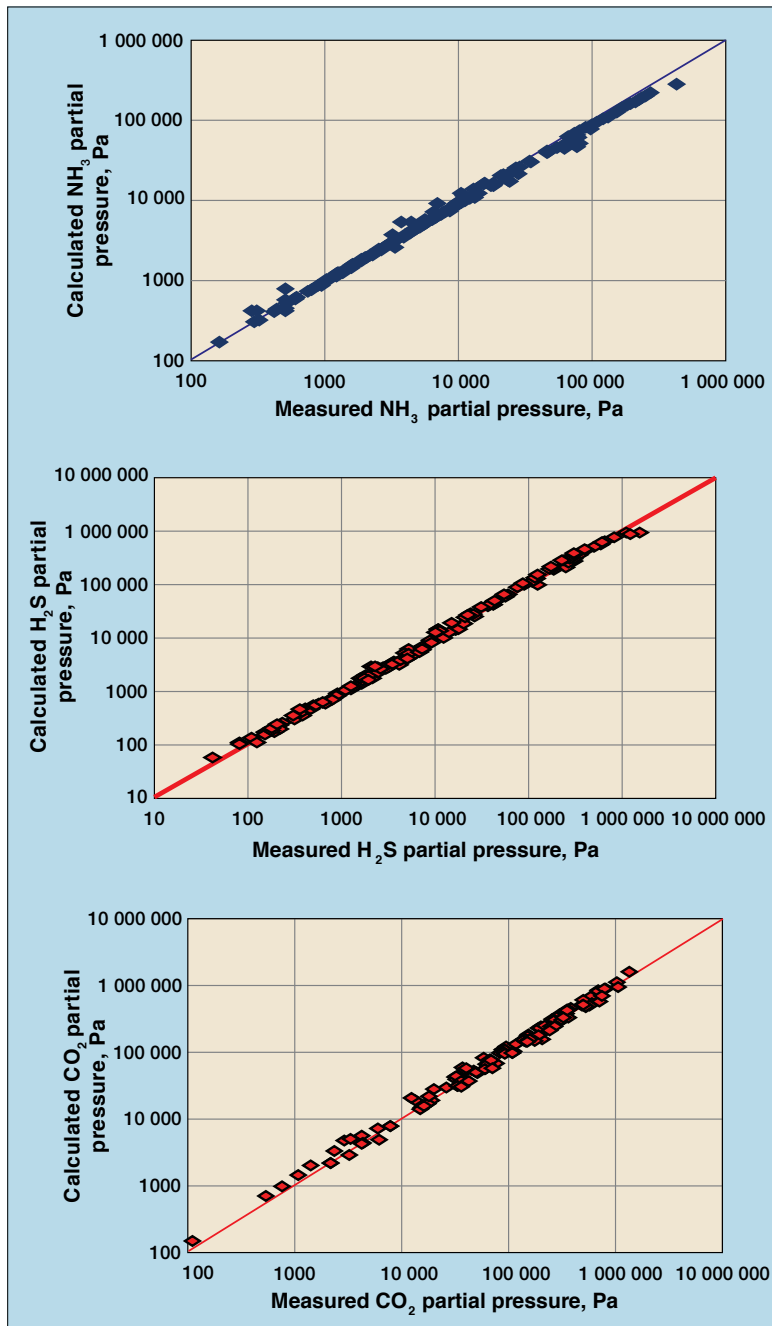

Figure 2 Parity plots of VLE data for the system $\text{NH}_3\text{-H}_2\text{S-CO}_2\text{-H}_2\text{O}$

model became available as part of the ProTreat simulation package. The remainder of this article uses the ProTreat simulator's sour water stripper model to reveal some rather surprising facts and behaviours of sour water strippers.

Phase equilibrium

The vapour pressure of ammonia and acid gases above sour water plays a key (but by no means the only) role in determining the extent to which a given column and process configuration will purify sour

water and how the process operating conditions affect the separation. We have developed an activity coefficient model for phase behaviour for sour water that uses the Deshmukh-Mather approach¹⁰ for activity coefficients, and the Peng-Robinson equation of state for the vapour. The thermodynamic model has been fitted to all public-domain-phase equilibrium data for the $\text{CO}_2\text{-H}_2\text{S-NH}_3\text{-H}_2\text{O}$ system, a total of some 550 separate experiments, most involving ammonia and either one or both of the acid gases H_2S and CO_2 . Figure 2 is a set of parity plots indicating partial pressure ranges in Pascals, and the goodness of fit.

Mass transfer rate model

The sour water stripper model in ProTreat deals with the separation of ammonia, the acid gases and water as governed by the particular mass transfer rate of each individual component. Ammonia is treated as reactive towards CO_2 in the same sense that any other primary or secondary amine is reactive, and transfer rates are determined by individual (vapour and liquid) phase mass transfer coefficients, interfacial areas and concentration difference driving forces. The details of mass transfer rate modelling have been described at length elsewhere^{5,6} and will not be repeated here. Suffice it to say, the kinetics of the $\text{NH}_3\text{-CO}_2$ reaction (see Equation 7) have been properly accounted for using known kinetic parameters and the usual enhancement factor approach. The resulting process model is a virtual plant on a computer in which all the fundamental physical and

chemical processes occurring are properly accounted for. The computer simulation is a direct one-for-one prediction of both column and process performance completely without recourse to user estimates of any parameters whatsoever. All that is required is the actual process flow sheet configuration, tower internals details and values for process parameters corresponding to such operating conditions as sour water flow and composition, tower pressures and imposed heat loads.

The sour water stripper model itself has been validated against at least a half dozen sets of stripper performance data by two refining companies and an engineering firm, with what were reported by them as excellent results. Using a virtual plant in the form of a precise computer model, the remainder of this article examines the effect of the steam-to-water ratio and stripper operating pressure on sour water stripper performance, as measured by such parameters as Murphree vapour efficiency and residual ammonia and H₂S in the stripped water. The simulation cases use live steam injection as the source of stripping vapour because this tends to be the most effective way of providing thermal energy for stripping; however, reboiled strippers add less make-up water and can be simulated just as easily.

Exploring strippers

Figure 1 shows the simplest possible configuration of a sour water stripper. For this exercise, the stripper contained 40 one-pass valve trays on 2ft

spacing with 2in weirs. Sour water was fed to Tray 6 (from the top), live 50 psig saturated steam entered below the bottom tray and, in all cases, the column was sized for 70% of jet and downcomer flood. Except for the case study involving stripper pressure, where a fixed temperature approach of 20°F was used, the sour water feed to the stripper was kept at 235°F. Table 1 gives the conditions of the sour water used for this case study.

Ratio of steam to sour water

Four steam rates were used — 0.78, 0.92, 1.20 and 1.48 lb/USgal — covering the range normally used in sour water stripping. (Gantz⁷ shows performance data for steam rates from 0.6 to 4.0 lb/USgal, although, commercially, rates at and above 1 lb/USgal are more usual.) One of the performance parameters of interest is the computed Murphree (1925) vapour-phase efficiency.⁸ Taylor and Kooijman⁹ define the Murphree vapour efficiency, $E_{i,n}^{mw}$, for component *i* on tray *n* (from the top) as:

$$E_{i,n}^{MV} = \frac{y_{i,n} - y_{i,n+1}}{y_{i,n} - y_{i,n+1}} \quad (8)$$

where *y* is the mole fraction

It should be noted that this is

not an overall tray efficiency. Tray overall efficiencies are based on ideal stage calculations to determine the number of theoretical (ideal) stages. ProTreat studiously avoids such calculations because, when combined with the averaging that is done through overall efficiencies, and the possible use of thermal efficiencies to force-match measured temperature profiles, they completely obscure what is really going on in SWSs. The interesting behaviours that occur in sour water strippers are caused by mass transfer effects; ideal stage approximations ignore tower internals as mass transfer devices and smooth out most of the physics of the real mass transfer device by considering only vapour-liquid equilibrium. The missing physics cannot be recovered by an overall tray efficiency for the column. Consequently, an ideal stage stripper model is, at best, only as good as its guessed efficiencies. The Murphree vapour efficiency, on the other hand, provides a quantitative measure of how close to perfect equilibrium each *real* tray actually operates. Unfortunately, a mass transfer rate model is needed to predict the Murphree efficiencies, so one might as well use a mass transfer model in the first place and avoid efficiencies altogether. The real value of the Murphree vapour efficiency is to show how far from equilibrium real trays perform and how radically performance can vary from tray to tray. It is worth emphasising that there is absolutely no relationship between Murphree vapour and overall tray efficiencies.

Sour water feed conditions	
Total flow, lb/h	150 000
Temperature, °F	235
Pressure, psia	70
Water, mol%	96.4
Hydrogen sulphide, mol%	1.5
Carbon dioxide, mol%	0.1
Ammonia, mol%	2.0

Table 1

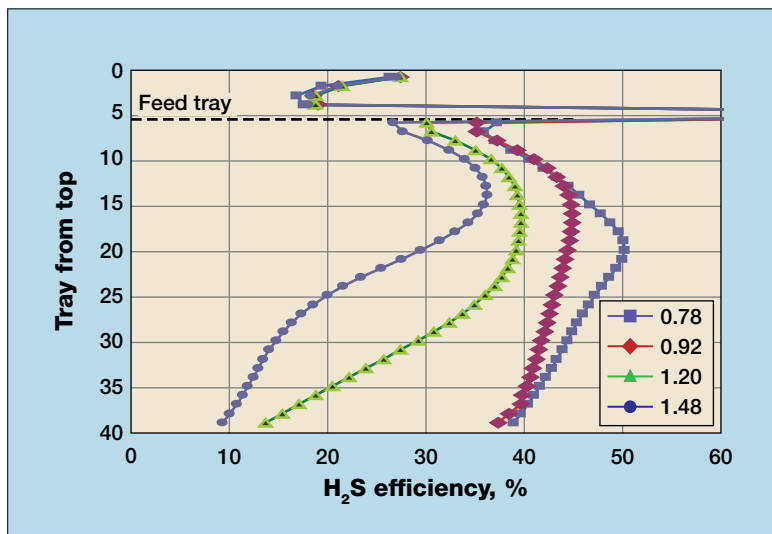

Figure 3 Calculated Murphree vapour efficiencies for H₂S

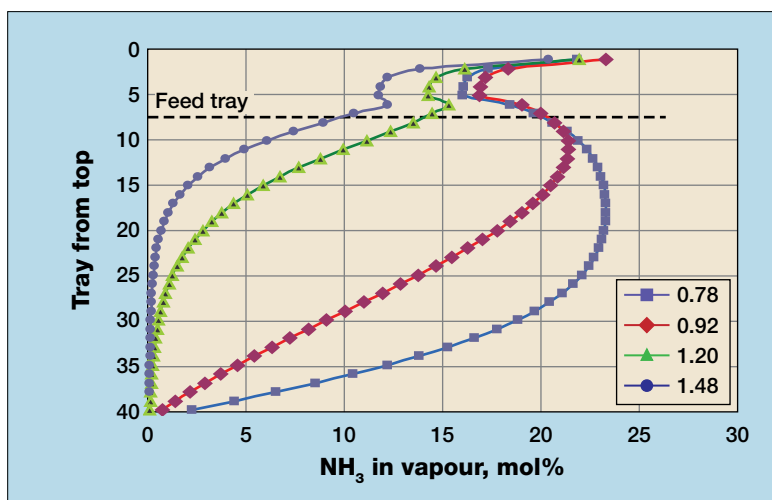

Figure 4 Ammonia concentration profiles in the SWS

As can be seen from Figure 3, H₂S efficiency varies enormously throughout the tower and is also a very sensitive function of the steam-to-sour-water ratio, especially when steam rates are relatively high. Generalising the Murphree vapour efficiency for H₂S is utterly impossible because it varies from a few per cent to 50%. Trays become extremely inefficient when the last vestiges of H₂S are being removed from the water.

Obviously, the tray count and the steam required depend heavily on the treated water specifications to be met. Thus, the designer is faced with a difficult decision, because more trays and more stripping energy lead to lower efficiency. These effects cannot be modelled or accounted for with an ideal stage model, even when a guessed overall tray efficiency is used. Providing optimal, cost-effective designs using theoretical stages is a

rather seat-of-the-pants enterprise.

Before tackling corresponding efficiencies for ammonia, it is revealing to look at the vapour- and liquid-phase concentration profiles of ammonia, as well as the simulated vapour profile compared directly with the equilibrium vapour composition. Figure 4 shows tray-by-tray profiles of the liquid- and vapour-phase mole percentages of ammonia. The surprising thing is the bulge, or maximum, displayed at boil-up rates at the low end of the range.

We have observed and reported the existence of similar maxima in ammonia concentration in the context of ammonia control in refinery amine units.¹¹ Indeed, it was found that in an amine regenerator only the bottom few trays were effective in stripping ammonia. In the present case of a sour water stripper, ammonia stripped in the lower part of the column is actually reabsorbed in the upper part because the H₂S is high enough there to react with and fix a significant part of the ammonia back into the liquid. When the steam-to-sour water ratio is high enough, however, the H₂S concentration is too low everywhere to remove enough ammonia to result in a maximum in the ammonia concentration. We note in passing that there is a strictly monotonic decrease in H₂S concentration as the sour water moves down the column.

When the boil-up rate is at the lower end of the spectrum and a maximum in ammonia concentration occurs away from the ends of the stripper,

the Murphree vapour efficiency for ammonia exhibits seemingly odd behaviour. Figure 5 shows very surprising efficiency trends from tray to tray at stripping steam rates of 0.78 and 0.92 lb steam/USgal. At the lowest steam rate, the apparent efficiency ranges from -100% to +120%, and at 0.92 lb/USgal the apparent efficiency reaches +200%. The reason is that the lines corresponding to actual and equilibrium vapour-phase mole fractions cross (as they must do because a bulge implies that stripping gives way to absorption at some point in the column) and they have a maximum on immediately adjacent trays rather than on the same tray. Figure 6 shows the actual (y) and equilibrium (y^*) lines for the steam rate of 0.92 lb/USgal, from which it can be seen that both exhibit a maximum, the lines cross, and they have peak values on different trays. Referring to Equation 8 (definition of efficiency), it is easy to see that if the numerator or denominator changes sign, or the concentration difference in the denominator becomes very small, apparent efficiencies can become not only large but negative.

At first glance, much of this odd efficiency behaviour may seem a little academic; however, when a constant efficiency is applied to an equilibrium-stage model, the maximum in ammonia concentration in the interior of the column, well away from the ends, will not be revealed and simulation results will tend to be quite optimistic in terms of sour water quality and stripped gas ammonia levels. This may

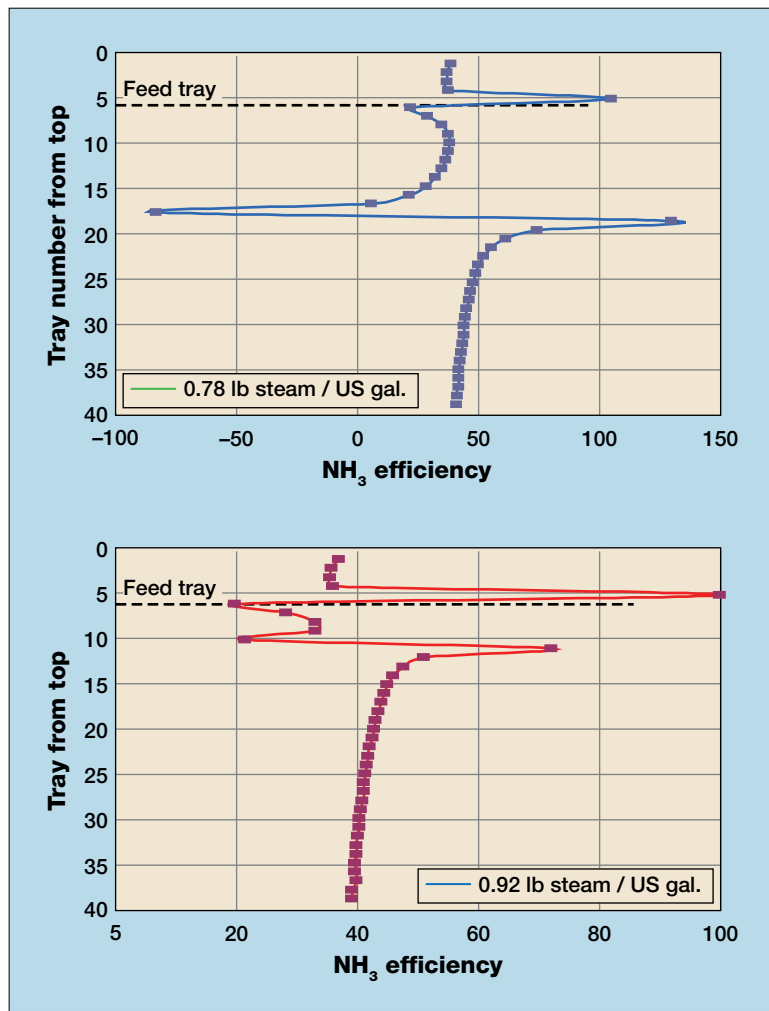

Figure 5 Murphree vapour efficiencies for ammonia at low steam rates

go some way to explaining the wide variations reported in tray efficiencies (15% to 45%) in this application. It is worth noting that when stripping steam rates are moderate to high, the Murphree efficiency turns out to be between 35% and 40%, with variations of only one or two percentage points across the whole column.

Effect of stripper pressure

From time to time, one hears it stated that higher stripper pressures favour sour water stripping, so we decided to put

this old wives' tale to the test. Table 2 shows the effect of column head pressure in residual ammonia and H₂S levels in stripped water for the same process configuration and sour water composition shown in Figure 1 and Table 1, respectively. The simulated performance corresponds to a steam rate of 25 000 lb/h of 50 psig steam (1.40 lb/USgal) with the cross exchanger set to a temperature approach of 20°F to minimise the effect of temperature differences across the stripping section. The table shows that, contrary to

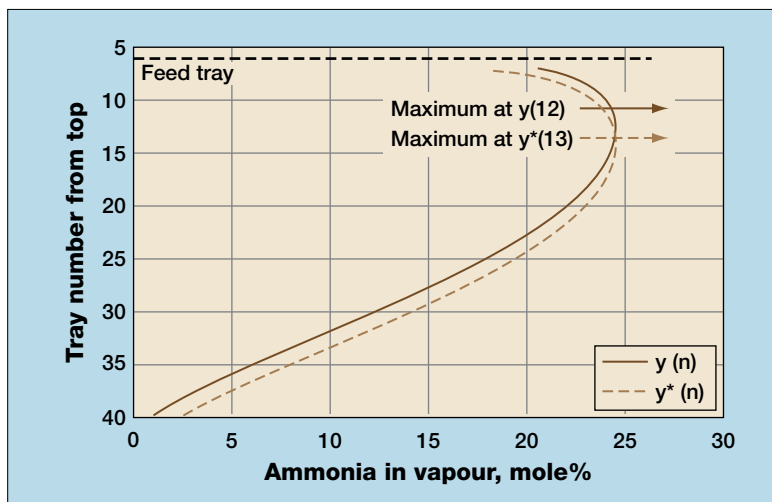

Figure 6 Actual and equilibrium ammonia concentrations in the vapour phase at low steam rates

anecdote, higher pressure has a negative (albeit relatively small) effect on water quality with respect to ammonia, but can cause an 80-fold increase in residual H_2S content of the stripped water under these conditions. Higher pressures do not seem to favour ammonia stripping, and they certainly have a negative effect on stripped water quality *vis-à-vis* H_2S .

Summary

Perhaps the most important message of this article is that genuine mass transfer rate-based modelling allows the construction of a virtual plant on a computer. There is no reliance on what might be termed

“fudge factors” to achieve agreement between calculations and reality.

A mass transfer rate-based sour water stripper model provides a virtual sour water stripper on a computer. Engineers can now design sour water stripper units with unprecedented accuracy and reliability. Plant operations personnel can answer a wide range of what-if questions to troubleshoot operations and to optimise existing units with complete confidence in the results.

After overall tray efficiencies, Murphree vapour efficiencies are probably the most commonly used type of efficiency for tray calculations.

Overall efficiencies are an invention of the 1920s, developed to allow ideal stage distillation calculations to approximate reality more closely, and as 90-year-old technology they have served the distillation business well. However, the whole equilibrium-stage approach was superseded by mass transfer rate calculation methods in the mid- to late 1980s, already more than 25 years ago. The gas treating industry deals with far more complex separations processes than distillation, but, unfortunately, it has been remarkably slow to catch on to the new technology. Genuine mass transfer rate-based simulation is an extremely powerful tool in gas treating.

There are several other messages that pertain directly to sour water stripping:

- H_2S efficiency varies enormously from tray to tray throughout a sour water stripper, and the Murphree efficiency is a very sensitive function of the steam-to-sour-water flow rate ratio. Any attempt to generalise H_2S component efficiency is utterly futile because of its huge variation from only a few per cent to 50% across a column and its dependency on the particular operating conditions of each unique situation

- With respect to efficiencies pertinent to H_2S stripping, the tray count and the steam required depend heavily on the treated water specifications to be met. Thus, the designer is faced with really quite a difficult decision — more trays and more stripping energy lead to lower efficiency. What and where is the balance? Should

Effect of stripper pressure on residual NH_3 and H_2S levels in stripped water

Stripper head pressure, psig	Treated water	
	Ammonia, ppmw	H_2S , ppmw
10	17.2	0.00002
15	21.1	0.00013
20	26.0	0.00058
25	31.5	0.00197

Table 2

one use more or less steam, and more or fewer trays? These effects cannot be accounted for with an ideal stage model, even when it uses efficiency. The process appears to be too complex to generalise into rules of thumb

- At stripping steam rates in the lower half of the normal range used in practice, it is quite possible for the ammonia concentration in a sour water stripper to show an enormous bulge or maximum in some part of the stripping section well away from the ends. At this bulge, the sour water stripper changes from acting as an ammonia stripper to an ammonia absorber. When (and where) the bulge occurs, there is a high enough H_2S concentration in the liquid to attract ammonia into the water phase and hold it there chemically. Again, ideal stage models even with efficiency do not show this kind of behaviour, and they can lead to either gross overdesign or to a complete mis-design, depending on the relative H_2S and ammonia concentrations in the sour water feed

- Murphree vapour efficiencies for ammonia in sour water strippers operating at low to moderate stripping steam rates can vary from large negative values to positive values well over 100%. At high steam rates, on the other hand, Murphree vapour efficiencies for ammonia stripping are typically 35% to 40%. This huge variation depending on steam rate and H_2S -to- NH_3 ratio may

go a long way towards explaining the wide range of 15% to 45% overall efficiency often quoted by practitioners

- Contrary to a commonly repeated anecdote, higher stripper pressures do not favour better ammonia stripping, and they certainly do not favour H_2S stripping where a factor of 80 loss in performance was predicted, even for the setup in this study.

In conclusion, this article has pointed out several aspects of sour water stripping that either do not seem to have been recognised heretofore, or that offer solid scientific explanations for previously observed and reported characteristics.

ProTreat is a registered mark of Optimized Gas Treating Inc.

References

- 1 Stevens D Mosher A, Ogg D, Fundamentals of sour water stripping, Brimstone Sulfur Recovery Symposium, Vail, CO, Sept 2007.
- 2 Hauser R, Kirkey R T, Refinery tests demonstrate fixed valve trays improve performance in sour water stripper, AIChE Spring National Meeting, 31 Mar 2003, New Orleans, LA T1-2E.
- 3 Quinlan M P, Hati A A, Processing NH_3 acid gas in a sulphur recovery unit, Proceedings of the 2010 Laurence Reid Gas Conditioning Conference, Norman, OK.
- 4 Asquith J, Moore A, sour water processing — balancing needs, Proceedings of the 2000 Brimstone Sulphur Recovery Symposium, Vail, CO.
- 5 Weiland R H, Sivasubramanian M S, Dingman J C, Effective amine technology: controlling selectivity, increasing slip and reducing sulphur, Laurence Reid Gas Conditioning Conference, Norman, OK, 2003.

- 6 Weiland R H, Dingman J C, Column design using mass transfer rate simulation, Laurence Reid Gas Conditioning Conference, Norman, OK, 2001.

- 7 Gantz R G, Sour water stripper operations, API Special Report, *Hydrocarbon Processing*, May 1975, 83.

- 8 Murphree E V, Graphical rectifying column calculations, *Ind. Eng. Chem.*, 17, 1925, 747-750 and 960-964.

- 9 Taylor R, Kooijman H, ChemSep Tutorial: Efficiencies, www.chemsep.com/downloads/docs/ChemSepTutorial_Efficiencies.pdf, downloaded 4 Jan 2012.

- 10 Deshmukh R D, Mather A E, A Mathematical model for equilibrium solubility of hydrogen sulphide and carbon dioxide in aqueous alkanolamine solutions, *Chem. Eng. Sci.*, 36, 1981, 355-362.

- 11 Hatcher N A, Weiland R H, Special treatment, *Hydrocarbon Engineering*, Jan 2012.

Ralph Weiland began working in gas treating as a graduate student in 1965 and has been an active researcher in this field ever since. He received BASc, MASc and PhD degrees in chemical engineering from the University of Toronto. He taught chemical engineering for 30 years at universities in Canada, Australia and the US, and spent 10 years doing mass transfer tray development with Koch-Glitsch LP in Dallas, TX. He established Optimized Gas Treating in 1992.

Email: ralph.weiland@ogtrt.com

Nathan Hatcher joined Optimized Gas Treating, Buda, Texas, as Vice-President, Technology Development, in 2009. He has spent almost his entire career in amine treating and sulphur recovery, and has extensive experience in the practical application of process simulation to operations, troubleshooting and training. He holds a BS in chemical engineering from the University of Kansas and is currently a member of the Amine Best Practices Group.

Email: nate.hatcher@ogtrt.com